

Instrument Panel Finish Panel — Center

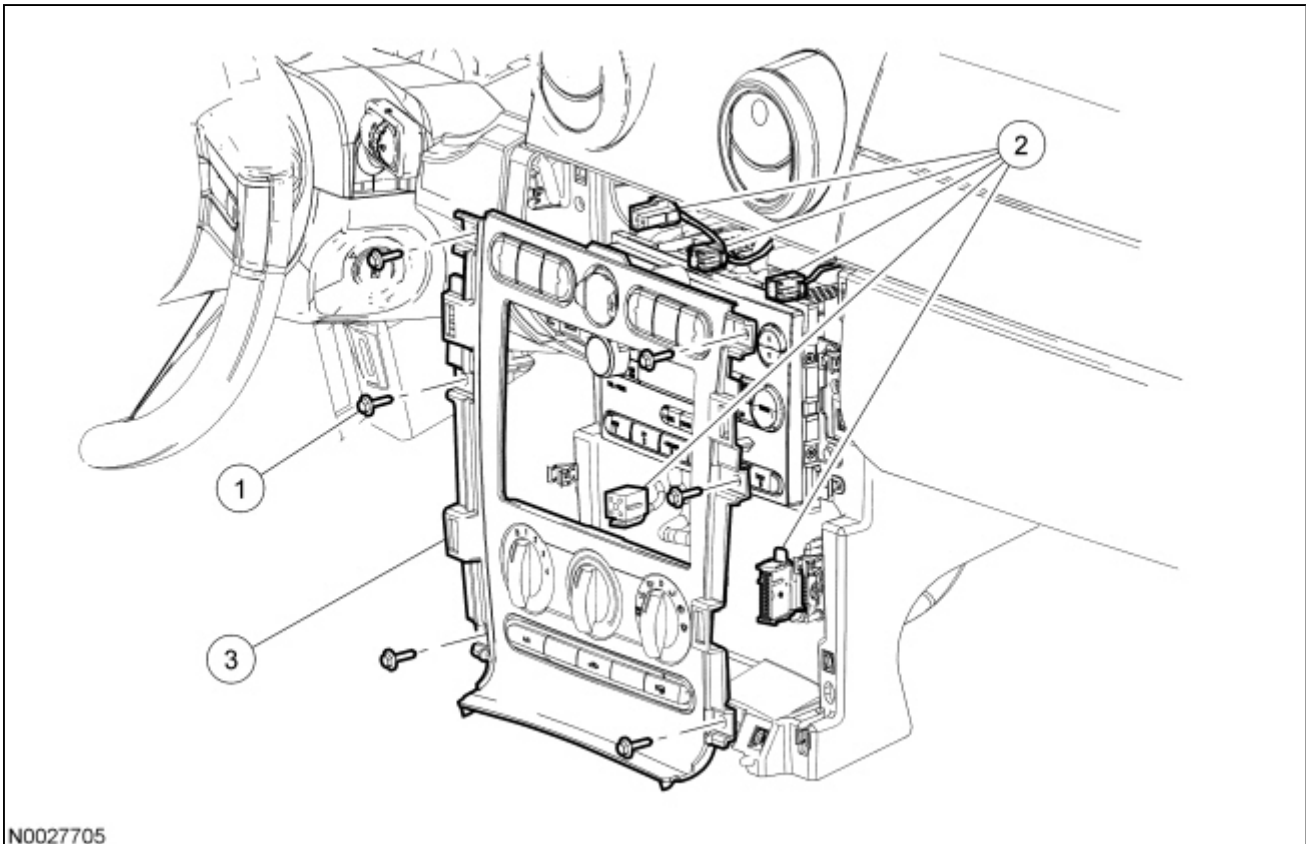

N0027705

Item	Part Number	Description
1	W705314	Instrument panel center finish panel screw (6 required)
2	—	Instrument panel center finish panel electrical connectors (5 required) (part of 14401)
3	6304302	Instrument panel center finish panel

Removal and Installation

1. **NOTE:** The ignition switch must be in the OFF position if disconnecting the Passenger Air Bag Deactivation (PAD) indicator electrical connector. Otherwise, a DTC will be set in the Restraints Control Module (RCM) memory and must be cleared before releasing the vehicle.

Turn the ignition OFF and wait at least one minute.

2. Remove the floor console. For additional information, refer to [Console — Floor](#) in this section.
3. Remove the 6 screws and remove the instrument panel center finish panel.
 - Disconnect the electrical connectors.
4. **NOTE:** Be sure that all climate control assembly electrical connectors are securely fastened before installing the center instrument panel finish panel.

To install, reverse the removal procedure.

- Make sure to align the trim panel retaining clips to the retaining clip holes in the instrument panel.

